

IMPROVED POWER QUALITY IN MV/LV POWER GRIDS USING POWER ELECTRONIC CONVERTERS

Prof. Eng. **Iulian M.T. BIROU** PhD¹, Prof. Eng. **Virgil MAIER** PhD²,
Prof. Eng. **Sorin Gh. PAVEL** PhD², Assist. Eng. **Ioana VESE** PhD¹

¹Technical University of Cluj Napoca
Faculty of Electrical Engineering, Department of Electrical Machines and Drives
²Technical University of Cluj Napoca
Faculty of Electrical Engineering, Department of Power Engineering and Management

REZUMAT. Problemele de calitate a energiei sunt deosebit de actuale. Compensarea armonicilor de tensiune/curent si controlul sau compensarea factorului de putere in retelele de medie/joasa tensiune se pot realiza astazi cu ajutorul convertoarelor electronice de putere. Pentru compensarea armonicilor, se folosesc configuratii bazate pe filtrele active de putere. Pentru conditionare activa a factorului de putere se pot utiliza convertoarele PWM de tensiune. Utilizind un convertor dual de tensiune, printr-o conditionare complexa a sa, pot fi rezolvate ambele probleme de calitate a energiei.

Cuvinte cheie: Calitatea energiei, convertoare electronice de putere, compensare de armonici si factor de putere.

ABSTRACT. Power quality problems are of high actuality. Voltage and current harmonics compensation as well as control or compensation of power factor in medium/low voltage grids can be today performed by using intelligent power electronic converters. Active filter based configurations are used for harmonic compensation introduced by nonlinear consumers. For the active power factor conditioning, PWM-controlled voltage converters can be used. To achieve both harmonics and power factor compensation, we need complex conditioning using intelligent controlled double-sided voltage converters.

Keywords: power quality, power electronic converters, voltage/current distortion and power factor compensation

1. INTRODUCTION

Nowadays, the concept of 'power quality' of electric energy has received a wider implication that the strict referring to the quality of energy in an electro-energetic system of which a customer is dependent in terms of optimal functioning. Therefore, the concept of power quality of electric energy used in technical literature correlates the issue related to the quality of electric supply with the issue related to the quality of the consumed energy, relatively [1],[2],[3]. Thus, one can discuss the following objective issues:

- the quality of the voltage waveform from the grid (voltage harmonic distortion);
- the quality of the input current waveform (current waveform distortion);
- the shift between the voltage and current waveform, respectively (power factor);

- random or periodical divergences of the effective value of the voltage (slow variations, fluctuations, voltage dips, short-term overvoltages etc);
- divergences of voltage frequency;
- electromagnetic compatibility of the costumers (especially electronic devices) and of grid consumers;
- unbalanced three-phase systems (voltage or current waveforms symmetry problems on different phases).

From all these aspects, the present paper intends to strictly analyze the power quality issues described in the first three items, i.e. the quality of current and voltage waveforms and the power factor, respectively.

Harmonic compensation of voltage or current in medium/low voltage grids can nowadays be done by using power electronic converters. Active filters based on PWM-controlled voltage converters can be used in various configurations, like presented in figure 1. On the other side, for power factor control or compensation, unity power factor rectifiers, stabilized

power sources or power converters for active conditioning can be used.

By using an intelligent power electronic converter, based on two mirror-placed PWM voltage converters, connected through a DC (voltage source) link, controlled each part by an own measurement and control unit, both harmonic compensation and power factor correction of the medium/low voltage grid can be achieved. Through this complex conditioning process of power networks, both compensating problems can be solved by closing the circle of power electronic converters used in power quality, like presented in figure 1.

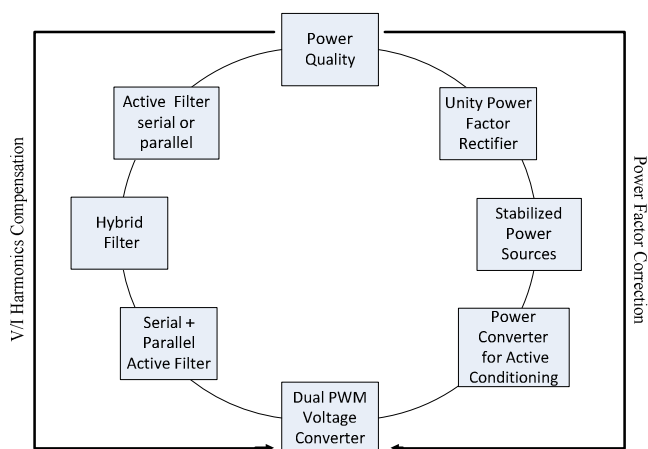

Fig.1. Unitary diagram of power electronic converters used in distortion and power factor compensation of MV/LV grids.

2. VOLTAGE AND CURRENT HARMONIC COMPENSATION

The presence of current and voltage harmonics is one of the main disturbance in electric supply networks, and their consequences on the implied user, nearby consumers and network are not favorable. Distorsion of the voltages and currents in a nonsinusoidal regime may be analyzed based on the following quantities [4],[5]:

Percentage of h-degree harmonic

$$S_h(\% \hat{o}) = \frac{C_h}{C_1} 100, \tag{1}$$

where, C_h is the effective value of the h-degree harmonic of the voltage or current, C_1 is the value of its fundamental.

Total harmonic distorsion.

$$THD = \frac{\sqrt{\sum_{h=2}^n C_h^2}}{C_1}, \tag{2}$$

whit n representing the number of considered harmonics.

Distortion factor

$$DIN = \frac{\sqrt{\sum_{h=2}^n C_h^2}}{\sqrt{\sum_{h=1}^n C_h^2}}. \tag{3}$$

Total demanded distortion

$$TDD = \frac{\sqrt{\sum_{h=2}^n I_h^2}}{I_N} \tag{4}$$

or

$$TDD = \frac{\sqrt{\sum_{h=2}^n I_h^2}}{I_L}, \tag{5}$$

where I_N and I_L are the nominal value of the current and the most demanded regime current, respectively.

Weighted distortion factor, by specific consumers like electric motors, is defined as following:

$$D_{wM} = \sqrt{\sum_{h=2}^{13} \frac{u_h^2}{h}}. \tag{6}$$

where

$$u_h = \frac{U_h}{U_1}. \tag{7}$$

The adverse effects induced by the presence of current and voltage harmonics in power systems are:

- the increase of the active power losses in wires and transformers with the related overheating effect;
- overloading of the neutral conductor;
- additional losses in magnetic materials (iron) due to hysteresis phenomenon;
- skin effect in conductors (due to high frequency harmonics);
- losses in dielectric materials, especially in capacitors with consequences in overloading them for the correction of the power factor;
- the occurrence of overvoltages in the power systems due to the resonance on certain voltage harmonics, appeared from the passive filters in the circuit;
- the occurrence of overloads in the power systems due to the resonance on certain harmonics with compensation capacitors.
- unpected operation of switches;
- malfunction of control devices;
- fail of remote signal transmission through the system protection relays and other control devices;

The main adverse effects of the current and voltages harmonics on the equipments in power system are:

- additional losses on electric machines;
- supplementary noises (disturbances) and vibrations in electric motors and other devices;
- the alteration of the neutral potential for the star connected equipment due to the $3n$ -degree harmonics;
- negative effects on the switches' and fuses' functioning
- influences on the electronic devices;
- influences on the measuring equipment.

3. THREE-PHASE ACTIVE POWER FILTERS IN HARMONIC CURRENT AND VOLTAGE COMPENSATION OF MV/LV GRIDS

Currently, given the impressive increase of the power of controlled static switches (bi-polar transistors, IGBTs, GTOs, MOSFETs etc), of their frequency and of the reliability of their switching elements, and at the same time given the rapid decrease of their costs, the attention in using active power filters has been therefore amplified, especially for MV-LV applications. Active filtering is a flexible solution to modification of the power supply configuration and it is valuable in applications where a fast response to the load variations is necessary. Active power filters represents, at this time, versatile tools, because they allow in some control configurations, both harmonics filtering and stabilization of the input current for unbalanced loads and compensation of the power factor, consequently. This ability is given by the major increase of the control possibilities of filters - a consequence to the obvious raise of digital signal processors' performances correlated with their reduction of price.

From structural point of view, the active power filter is, in fact, a controlled static frequency power converter, voltage or current source type, which from topological point of view, allow, when using appropriate control techniques, the realization of the filtering process of the harmonics in the consumers connection point (CCP) at the grid, like presented in figure 2. These electronic devices, named measurement and control unit analyze the harmonic current given by a nonlinear load and generate exactly the distorting residue in the consequent period. In this manner, the

distorting residue is supplied by the active filter, and the fundamental current is taken from the grid.

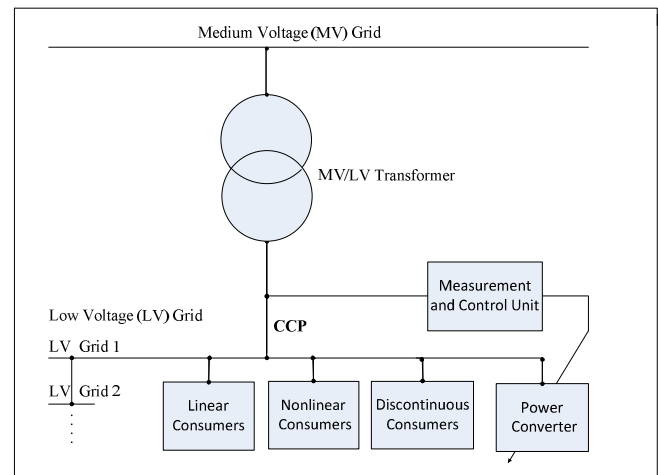

Fig.2. Power grid diagram with harmonics compensation based on PWM controlled power electronic converters

Therefore, the grid is discharged by the nonlinear load induced current harmonics. If the residual current of the nonlinear load overpasses the filtering possibilities of the active filter, then the active filter executes only the necessary correction and some of the current harmonics are taken by the grid. Active filters function only for those current harmonics that are present in the load current, i.e. in the consumers connection point (CCP). Active power filter may be connected in the grid under the next configurations:

- active serial power filter
- hybrid power filter, obtained by combining different configurations of an active filter with a passive one;
- parallel active filter
- active serial power filter coupled on the intermediary circuit with a active parallel filter.

Active power filters have many advantages respect to the passive one, advantages that have been imposed as competitive, modern, reliable filtering solution. [4]:

- they may reduce the THD at very low values, that integrates between the normative limits;
- they can't be overloaded because of the input harmonic currents by other distorting loads;
- the currents to be compensated may be selected;
- the harmonic distortion and/or the power factor may be compensated simultaneously and independently (they may even eliminate the reactive current, not only the harmonic currents);
- the precision of the compensation is higher;
- they don't produce resonances with the distribution power systems;

- they have important flexibility regarding the placement and the connection schemes.

The active filter represents a convenient solution, especially in systems where the harmonic amount cannot be predictable because of the frequent change of the location and of the equipment type. The main drawback of using active power is represented by the necessity of using completely controlled semiconductor elements, with a high switching frequency that provoke high frequency perturbations that may induce electromagnetic interferences in the distribution power system and may defectively influence the communication networks.

3.1. Parallel active filter

The most utilized active filter configuration is the parallel one, in which the voltage source PWM static converter behaves, respect to the grid, as a current source, compensating the harmonic currents from the load current. The active power filter connection at the grid is always done through an interface filter that, in its simpler form is an power inductivity. The schematic configuration of the parallel active filter connected to the grid is presented in figure 3, where the active filter is represented by the PWM power converter 1, the connection device block of converter 1 is the interface filter and the power converter 2 and connection device do not exist.

In order that only by the fundamental component of the load current to pass through the source, and the high degree harmonics to be eliminated, the parallel active filter must inject in the grid a compensation current; this must represent the sum of all harmonics of the distorted current. Expanding the ration of decomposition of the distorted current into a component likely to be found in the grid – usually shifted with the phase voltage and with the same waveform and a component likely to be eliminated, it may be concluded that by adopting a proper control of the static converter, the active filter is capable to absorb from the grid an identical and opposite current waveform with the unwanted component of the load current from the grid. The control strategy is based on measurements of grid parameters and is performed by the measurement and control unit presented in fig. 3.

Thus, concluding, the parallel active filter may overcome the perturbing currents (harmonics, reactive or unbalanced) generated by the pollutant loads to interfere in the grid, upstream the common connection point. Unlike the serial configurations, the parallel active filter has the advantage of being passed by the compensated current only, plus a small part of the

active fundamental current, necessary for the compensation of the losses.

3.2. Combination of serial active filter and parallel active filter

The topology obtained from the parallel connection of a serial active filter and a parallel one on a circuit element of energy storage of capacitor type, is part of some modern and advanced equipments of compensation, referred in the literature as “universal conditioners”. The parallel active filter is always connected on the load side, and the serial one on the power supply side. The topology is presented in fig. 3, where the serial active filter is the PWM power converter 1, his connection device is a power transformer, the parallel active filter is the PWM power converter 2 and his connection device is the interface filter. According to the compensation functions that are done in the power system, the structure is known in the literature under three designations [4], [5]:

- Unified Power Flow Controller (UPFC) is used in the transmission grids for the control of active and reactive power flow, of voltage level at the grid's frequency.
- Unified Power Quality Conditioner (UPQC) is used in the distribution systems for the simultaneous compensation of the current and voltage harmonics and their unbalance. It is the most flexible equipment for compensation of the harmonics and it has good performances from dynamic point of view.
- Universal Power Line Conditioner (UPLC) combines the functions of UPFC and UPQC through a control method based on the phasors theory of the powers.

When the combination of serial APF and parallel APF is used as a united compensator for the energy quality, the parallel active filter is connected as close to the nonlinear load and behaves like a controlled current source, while the serial active filter behaves like a controlled voltage source. By adopting a proper control, combining the functions and advantages of the two filters, UPQC may assure sinusoidal voltage and current shifted with the voltage, starting from the distorting current and voltage of the grid. The functions that a serial APF performs in a UPQC are: the compensation of the voltage distortions (harmonics and asymmetry components at fundamental frequency); harmonic isolation of the source; the stability improvement for the system, by eliminating the oscillations from the power system. The functions that the parallel APF performs are: the compensation of the current distortions (harmonics and asymmetry components at

fundamental frequency); to compensate the reactive power of the load; to assure the control of the voltage on the capacitor from the d.c. circuit.

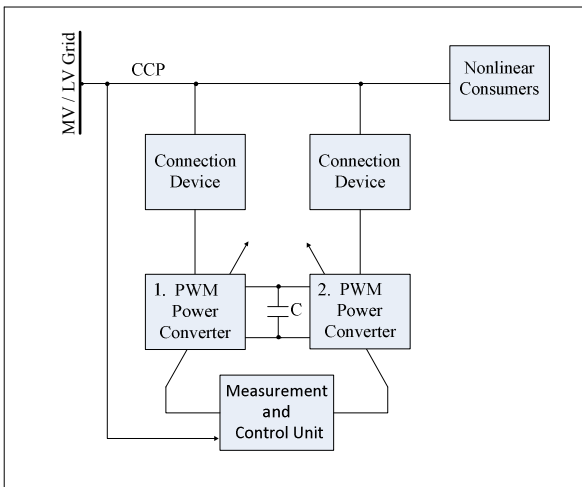

Fig.3. General structure of different configurations using power converters, like: active filter configurations (serial, parallel, serial and parallel), active and complex conditioning

3.3. Control strategies for the three-phase active power filters

The force scheme contains the voltage inverter, the capacitor on the d.c. part and the interface filter. The inverter has the role of furnishing the desired currents for the filtering of the load currents and therefore, the compensation of the distorting power, corresponding to the filtered current harmonics, and of the reactive power, if needed. At the same time, it must assure the permanently reload of the capacitor, such that the system losses to be compensated. The interface filter is a passive filter of first degree and it has the role to prevent the high frequency currents induced by the PWM control of the inverter, to pass through the power supply. It has also an important role in obtaining performances of high filtering [6].

The control part contains the calculation block of the current that must be compensated, the controller for the voltage on the d.c. part of the static converter, the current controller and the command block of the inverter and is presented in figure 3 by the measurement and control unit block. The calculation block of the current that has to be compensated, implements a certain mathematical method and furnish the reference current of the active power filter of fundamental frequency.

The control of the d.c. voltage is done through the control of the active power flux on the compensation capacitor, and the compensation of the losses through the active power filter, respectively. The command block of

the inverter furnishes the control signals that are applied on the drivers of the semiconductor elements.

The measurement part contains the sensors and the specific acquisition and processing blocks for the necessary quantities. Generally, they are the voltages of the three phase system, the voltage on the compensation capacitor, the load currents and the currents at the filter output. The used sensors must have on the a.c. part a small response time, the frequency being imposed for at least the double of the frequency of the higher degree harmonic to be compensated.

4. POWER ELECTRONIC CONVERTERS USED FOR COMPENSATING OR CONTROLLING THE POWER FACTOR IN MV/LV GRIDS

For power factor compensations of MV/LV grids, a wide range of solutions are now applied. The paper focuses on solutions based on power electronic converters. This devices are located in the common connection points (CCP) of MV/LV system by the user or, if the case, in agreement with the large consumers. For smaller powers, as a reaction to the limitations more and more severe imposed by the existing standards and regulations, it have appeared converters with reduced pollution effect on the grid. These converters use the advantages offered by the existance of fast and high power electronic switching devices, which combined with control strategies based on time pulse modulation (PWM), may assure a “grid-friendly” behaviour of these converters [7], and it contains, like presented in figure 1:

- PWM rectifiers with unitary power factor;
- stabilized power sources with power factor correction;
- PWM power electronic converters used for active conditioning of the grid;
- dual PWM voltage converters for complex conditioning of the power grid.

4.1. Active and complex conditioning of the public network using PWM modulated power electronic converters

At this moment, from the point of view of behaving respect to the a.c. grid, the applied techniques for the consumers is the one of active compensation of the power factor. In this case, a friendly behaviour is assured for the network, but the undesired effects of other nonlinear consumers from the network are not

eliminated. Starting from the current shaping method, applied for the active correction of power factor, in the case of the inverters with the unitary power factor and of the switching sources, it is possible to perform a modification of the control method, for obtaining the reference current in such manner, that a phase shift appears between the voltage of the grid and the input current of the converter and following the equipment have inductivity or capacitor character, respect to the shift. This operation mode is called active conditioning of the a.c network.[7], [8]. For compensating the power factor it is necessary the knowledge of the used/generated reactive power from other costumers with reactive character in the network.

In order to assist the network when the voltages and the currents in the network are distorted, the use of some more complex control strategies is imposed for the converters that will be functioning this time in the so-called mode of complex conditioning of the a.c. network, by using the dual PWM voltage converter presented as the closing cercle element of figure 1 and having the block diagram presented in figure 3 where both PWM voltage converters are used controlled by complex measurement and control unit. In this case the converter will have a secondary function of active power filter, based on obtaining the reference current signal at the PWM converter level by application of Fourier analysis. In such manner, the feeding voltage of the convertor is analyzed with Fourier function in order to obtain information on the harmonic containing. The amplitudes and the phases of the voltage harmonics may be determined, then, they are processed in order to obtain a reference current signal, containing similar harmonics. This method may be considered as a modified variant of the active correction of the power factor method, for which the current reference signal has now a larger amount of harmonics. The difference from converter with the active correction of the power factor is that the processing block of signals is differently constructed. It is a simple to implement procedure, the implementation costs are low, but it has the drawback that the filtering performances are under the network parameters' influence. The peculiarity of the method is that the input current is elaborated by analyzing the network voltage and not the line current, like the case for active power filters. If this voltage is distorted because of the harmonic currents in the network, the input current in the pre-converter is also modified in order not to contain harmonics.

For the complex conditioning, on must know the amount of harmonics of the used currents by others in order to define an input current with identical amount of harmonics, but having the 180 shifting. In this scope, a

system of monitoring and conditioning from distance the network is used, placed at the common connection point, like presented in figure 2. It measures the currents and it calculates the instantaneous powers from the circuit or it identify the current harmonics from the network, these information being used at controlling the converters.

Therefore, the converters may have a distance-controlled behaviour that follows the compensation of the reactive power from the circuit. Similary, for the complex conditioning, the detection of the harmonics, lead to imposing a filter behaviour to the converter. The simplified block scheme of this type of network is presented in figure 3. One of this method's problem, that must be resolved, is the distance transmission of the measured data at the PCC. These solutions imply modifications brought to the level of control circuits of the converts that must receive the information from the common connection point and to modify its behavior correspondingly [8]. The advantage of these methods is that they may completely compensate the reactive power flowing, in the case of active conditioning and may completely eliminate the distortions in the case of complex conditioning. These, of course, if the installed apparent power/active power ratio permits it.

BIBLIOGRAPHY

- [1] H. Akagi – ‘New trends in Active Filters for Power Conditioning’, In *IEEE Transactions on Industrial Applications*, 32, (6), 1996, pp.1312-1322.
- [2] V. Maier, S. Pavel, C. Maier - ‘*Ingineria calității și protecția mediului*’, Editura U.T. Press, Cluj-Napoca, 2007.
- [3] G. Rață – ‘*Regimul deformant la consumatorii industriali*’, Editura Matrix Rom, București, 2008.
- [4] A. Bitoleanu, M. Popescu – ‘*Filtre active de putere*’, Editura Universitaria, Craiova, 2010.
- [5] H. Akagi, E. Watanabe, M. Aredes – ‘*Instantaneous Power Theory and Applications to Power Conditioning*’, Willey-IEEE Press, 2007.
- [6] D. Roiu - ‘*Cercetări privind îmbunătățirea structurilor echipamentelor electronice de putere în vederea reducerii pierderilor în motorul electric și rețeaua de alimentare*’, Teză de doctorat, Universitatea Tehnică „Gheorghe Asachi”, Facultatea de Inginerie Electrică, Energetică și Informatică Aplicată, Iași, 2010.
- [7] R. Paku - ‘*Contribuții la cercetarea și implementarea sistemelor de condiționare activă a rețelei de curent alternativ cu ajutorul convertoarelor de curent continuu controlate prin modulare în durată a impulsurilor*’, Teză de doctorat, Universitatea Tehnică Cluj-Napoca, Facultatea de Inginerie Electrică, Cluj-Napoca, 2010.
- [8] P. Balogh - ‘*Studii și cercatări privind condiționarea rețelei publice de curent alternativ prin corectare complexă a factorului de putere*’. Teză de doctorat, Universitatea Tehnică Cluj-Napoca, Facultatea de Inginerie Electrică, Cluj-Napoca, 2011.